

Reference Architecture for Active System 800 with Microsoft Hyper-V

Release 1.0 for Dell PowerEdge 12th Generation Blade Servers, Dell Force10 Switches, Dell EqualLogic iSCSI SAN, Microsoft Windows Server 2012 with Hyper-V role and Dell Active System Manager

Dell Global Solutions Engineering

Revision: A00

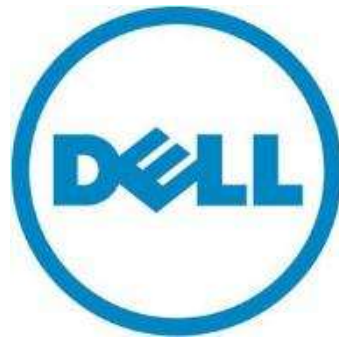

This document is for informational purposes only and may contain typographical errors and technical inaccuracies. The content is provided as is, without express or implied warranties of any kind.

© 2013 Dell Inc. All rights reserved. Dell and its affiliates cannot be responsible for errors or omissions in typography or photography. *Dell, the Dell logo, Force10, EqualLogic, OpenManage, KACE* and *PowerEdge* are trademarks of Dell Inc. *Intel* and *Xeon* are registered trademarks of Intel Corporation in the U.S. and other countries. *Microsoft, Windows, Hyper-V, Active Directory, and Windows Server* are either trademarks or registered trademarks of Microsoft Corporation in the United States and/or other countries. Other trademarks and trade names may be used in this document to refer to either the entities claiming the marks and names or their products. Dell disclaims proprietary interest in the marks and names of others.

March 2013 | Rev A00

Revision History

Revision	Description	Date
A00	Initial Version	March 2013

Table of Contents

1	Introduction.....	1
2	Audience.....	1
3	Solution Overview	2
4	Design Principles	6
5	Prerequisites and Datacenter Planning	7
6	Architecture	8
6.1	Dell Blade Network Architecture	10
6.2	Server / Blade Network Connectivity.....	10
6.3	Server / Blade Storage Connectivity.....	14
6.4	Server / Blade HA and Redundancy	14
6.5	Storage Architecture	15
7	Management Infrastructure	18
7.1	Active System Manager.....	20
7.2	Microsoft Windows Server 2012 Built-In tools	20
7.3	Dell OpenManage Essentials	22
7.4	Dell EqualLogic SAN HQ	23
7.5	Out-of-band Management: CMC and iDRAC	24
7.6	System Center 2012 SP1	24
7.7	Dell System Center 2012 Integration	25
7.8	Out-Of-Band Management Connectivity.....	25
8	Scalability	26
9	Delivery Model.....	26
10	References.....	29
10.1	Dell PowerEdge Server Documentation and Hardware/Software Updates	29
10.2	Dell Force10 Switch Documentation and Firmware Updates	29
10.3	Dell EqualLogic:	29
10.4	Dell Virtualization Documentation	29
10.5	Microsoft® Hyper-V Documentation	30
10.6	Microsoft® Management Software	30

Figures

Figure 1: Overview of Dell Blade Servers, Dell Force10 network switches, Dell EqualLogic PS6110 Series Storage, and Software	2
Figure 2: Converged Network Topology (Logical View) with optional 2nd Chassis	9

Reference Architecture for Active System 800m with Hyper-V:

Figure 3: I/O Connectivity for M620 Blade Server	10
Figure 4: Converged Fabric Overview.....	11
Figure 5: Converged Network configuration for Compute Dell PowerEdge M620 Blade Servers.....	12
Figure 6: Converged Network Configuration for Management of Dell PowerEdge R620 Servers	13
Figure 7: Active System SAN Connectivity Overview	16
Figure 8: Management Architecture	19
Figure 9: Manage Active System 800m with Server Manager	21
Figure 10: Resources Measuring in PowerShell 3.0	22
Figure 11: OME Dashboard	23
Figure 12: Connectivity of OOB management components.	26
Figure 13: Dell Active System 800m Rack and Component Overview	27
Figure 14: Dell Active System 800m Maximum 2 Rack Component Overview	28

Tables

Table 1: Solution Components	3
Table 2: Traffic Description	13
Table 3: Sample VLAN and subnet configuration	14

1 Introduction

Dell™ Active Infrastructure is a family of converged infrastructure solutions that combine servers, storage, networking, and infrastructure management into an integrated and optimized system that provides general purpose virtualized resource pools. Active Infrastructure leverages Dell innovations including unified management with Active System Manager, converged LAN/SAN fabrics, and modular server architecture for the ultimate converged infrastructure solution. Active Infrastructure helps IT rapidly respond to dynamic business demands, maximize data center efficiency, and strengthen IT service quality.

The Active System 800 solution, a member of Dell Active Infrastructure family, is a converged infrastructure solution that has been designed and validated by Dell Engineering. It is available racked, cabled, and delivered to your site to speed deployment. Dell Services deploys and configures the system tailored for business needs and ready for integration into your datacenter. Active System 800 is Dell's first Active Infrastructure System to include Dell PowerEdge™ M620 Blades, iSCSI / 10GbE unified fabric switching, Dell EqualLogic™ PS6110 Series 10GbE iSCSI storage, and Dell Active System Manager to build private cloud solutions that address key needs of the mid to large data center. The backbone of this solution is driven by features associated with a unified fabric consisting of both LAN and SAN traffic on a consolidated network architecture via Data Center Bridging (DCB). The solution is offered in configurations with either VMware® vSphere™ or Microsoft® Windows Server® 2012 with Hyper-V® role enabled Hypervisors. The VMware vSphere solution is the Active System 800v and the Microsoft Hyper-V solution is the Active System 800m. This document defines the reference architecture for Active System 800m.

The Active System configurations vary in the number of Dell PowerEdge M620 blade servers and Dell EqualLogic PS6110 Series storage arrays to meet virtualization resource needs.

2 Audience

This document provides an overview of the Active System 800 solution. Readers, including CTOs and IT managers, can use this document to understand the overview and scope of the solution. IT administrators and managers can use this document to understand the solution architecture.

3 Solution Overview

This section provides a high-level product overview of the major components of the Active System 800 as illustrated in Figure 1. Readers can skip the sections of products with which they are familiar.

Figure 1: Overview of Dell Blade Servers, Dell Force10 network switches, Dell EqualLogic PS6110 Series Storage, and Software









	<p>Microsoft Windows Server 2012</p> <ul style="list-style-type: none"> • Failover Clustering (High Availability and Live Migration) • Hyper-V Role Enabled • Hyper-V and Cluster Management tools
	<p>Management Components</p> <ul style="list-style-type: none"> • Dell Active System Manager - Hardware provisioning and management • Dell EqualLogic SAN-HQ - SAN monitoring • Dell OpenManage Essentials - Hardware monitoring
	<ul style="list-style-type: none"> • Optional System Center Virtual Machine Manager - Hypervisor and VM management
	<p>Compute Cluster - Dell PowerEdge Blade Servers</p> <ul style="list-style-type: none"> • Energy efficient Dell PowerEdge M1000e enclosure • Up to 32 Dell PowerEdge M620 blade servers • CPU: 2x Intel® Xeon® 2.2GHz 95W 8C • Memory: 128 GB (16x8GB) 1333 MHz RDIMMs • NDC: BCM 57810-k (2x10GbE 10GBASE-KR) • PowerEdge M I/O Aggregator • iDRAC7 Enterprise
	<p>Management Cluster - Dell PowerEdge R620</p> <ul style="list-style-type: none"> • CPU: 2x Intel® Xeon 2.2GHz 95W 8C • Memory: 128 GB (16x8GB) 1333 MHz RDIMMs • NDC: BCM 5720 (4x 1GbE RJ-45) • NIC: BCM 57810 PCI-e (2x 10GbE SFP+) • iDRAC: iDRAC7 Enterprise
	<p>Dell Force10 S4810 48x 10GbE + 4x 40GbE Ports</p> <ul style="list-style-type: none"> • 2x S4810 High-density 48 port 10GbE switches for converged LAN and SAN traffic • 80GbE ISL between the switches
	<p>Dell Force10 S55 44x 1GbE + 4x SFP Ports</p> <ul style="list-style-type: none"> • 10/100/1000MbE Out of Band (OOB) Mgmt Traffic
	<p>Dell EqualLogic PS6110 Series iSCSI Storage</p> <ul style="list-style-type: none"> • 10GbE Controllers with up to 8 Arrays • Default Solution <ul style="list-style-type: none"> 1x PS6100X per 4x hosts with (24) 2.5" 900GB 10k

Table 1 below describes the key solution components and the roles served.

Table 1: Solution Components

Component	Description	Role
Compute Cluster	PowerEdge M620 blade servers running Windows Server 2012 Datacenter Edition with Hyper-V role enabled	Host highly-available virtual machines (VMs)
Management Cluster	PowerEdge R620 servers running Windows Server® 2012 Datacenter Edition with Hyper-V role enabled.	Host management VMs: Dell Active system Manager, optional System Center Virtual Machine Manager (VMM) 2012 SP1, EqualLogic SAN HQ and Dell OpenManage Essentials
Storage	Dell EqualLogic PS6110 Series controllers with 24 bay 2.5” SAS enclosures or 12 Bay 3.5” SAS enclosures	Provide shared storage for the Hyper-V clusters
Converged Network Switches	Two Force10 S4810 and Dell PowerEdge M I/O Aggregator modules for the blade chassis	Support VM, Live Migration, Management, iSCSI and Cluster traffic
OOB management Switch	One Force10 S55	Provide Management OOB management connectivity

Microsoft Windows Server 2012: Microsoft® Windows Server® 2012 is Microsoft’s flagship server operating system which provides the Hyper-V® virtualization platform. Hyper-V provides a virtualization platform that can consolidate Windows® and Linux workloads enabling IT managers the ability to more fully utilize their available hardware resources. The following Windows Server 2012 features are available in this solution.

Dell Active System Manager: Active System Manager sits at the center of Active System, and simplifies infrastructure configuration, collapses management tools, and drives automation and consistency. Through capabilities such as template-based provisioning, automated configuration, and infrastructure lifecycle management, Active System Manager enables IT to respond rapidly to business needs, maximize data center efficiency, and strengthen quality of IT service delivery.

The software enables a cloud like environment, and supports pre-built provisioning templates and custom orchestrated workflows for a wide range of physical or virtual environments. Use and features of the Dell Active System Manager will be described in more detail in subsequent sections of this document. Additional detail can also be found on the Dell website at: [Dell Active System Manager](#).

Note: Active System Manager offers limited functionality on Microsoft Hyper-V platforms with Active System Manager version 7.0. The capabilities and benefits outlined above will be available on the Microsoft Hyper-V platforms with the Active System Manager version 7.1 scheduled for release in mid 2013.

Dell OpenManage Essentials: The Dell OpenManage™ Essentials Console provides a single, easy-to-use, one-to-many interface through which to manage resources in multivendor operating system and hypervisor environments. It automates basic repetitive hardware management tasks – like discovery,

monitoring and updates – for Dell servers, storage, and network systems. OME employs the embedded management of Dell PowerEdge™ servers – Integrated Dell Remote Access Controller 7 (iDRAC7) with Lifecycle Controller – to enable agent-free remote management and monitoring of server hardware components like storage, networking, processors, and memory. For more information on Dell Enterprise Management and OpenManage Essentials, see <http://content.dell.com/us/en/enterprise/data-center-system-management>.

Dell EqualLogic SAN Headquarters (SAN HQ): SAN HQ provides in-depth reporting and analysis tools. With the information you get from SAN HQ, you can better customize, protect, and optimize your storage. Dell EqualLogic SAN HQ provides consolidated performance and robust event monitoring across multiple Dell EqualLogic groups. If action is required, the Dell EqualLogic Group Manager can be launched directly from SAN HQ giving you the ability to quickly adjust storage systems to meet business needs. For more information about Dell EqualLogic storage and SAN HQ, see <http://www.dell.com/us/enterprise/p/equallogic-products>.

Optional Microsoft System Center 2012 Service Pack 1: System Center 2012 is Microsoft's systems management platform which helps to monitor, manage, deploy, backup, and more. System Center 2012 Service Pack 1 (SP1) introduces support for Windows Server 2012, enabling you to take advantage of Windows Server 2012's new features in a managed environment. This solution utilizes either a customer provided or a trial version of System Center 2012 SP1 and focuses on Virtual Machine Manager 2012. Further information on all Microsoft System Center components can be found at www.microsoft.com/systemcenter.

System Center 2012 Virtual Machine Manager (VMM): VMM is Microsoft's centralized virtualization manager. It provides the fundamental services for creating and managing virtual machines, optimizing resources, and rapid deployment of virtualized infrastructure.

VMM 2012 Service Pack 1 supports the new features included in Windows Server 2012: network virtualization, VHDX support, SMB 3.0 file share, and the enhancements on storage management, host provisioning, and Live Migration.

Dell PowerEdge Blade Modular Enclosure: The Dell PowerEdge M1000e is a high-density, energy-efficient blade chassis that supports up to sixteen half-height blade servers, or eight full-height blade servers, and six I/O modules. A high-speed passive mid-plane connects the server modules to the I/O modules, management, and power in the rear of the chassis. The enclosure includes a flip-out LCD screen (for local configuration), six hot-pluggable/redundant power supplies, and nine hot-pluggable N+1 redundant fan modules.

Blade Servers: The Dell PowerEdge M1000e Blade Server Chassis supports the Dell PowerEdge M620 blade servers based on Intel® Xeon® E5 series processors. Dell's embedded management houses the tools and enablement pieces for management directly on the server, allowing administrators to perform a complete set of provisioning functions from a single, intuitive interface.

I/O Modules: The enclosure provides three redundant fabrics using six I/O modules. The modules can be populated with Ethernet switches, Dell Power Edge M I/O Aggregator, Fibre Channel (FC), and pass-through modules.

Chassis Management: The Dell PowerEdge M1000e has integrated management through a redundant Chassis Management Controller (CMC) module for enclosure management and integrated keyboard, video, and mouse (iKVM) modules.

Embedded Management with Dell's Lifecycle Controller: The Lifecycle Controller is the engine for advanced embedded management and is delivered as part of iDRAC7 Enterprise in Dell PowerEdge 12th generation blade servers. For more information on Dell Lifecycle Controllers and blade servers, see <http://content.dell.com/us/en/enterprise/dcsm-embedded-management> and Dell.com/blades.

Dell PowerEdge M I/O Aggregator (I/OA): The Dell PowerEdge M I/O Aggregator is a flexible 1/10GbE aggregation device that is automated and preconfigured for easy “plug and play” deployment into converged iSCSI and FCoE networks. The key feature of the PowerEdge M I/OA is that all VLANs are allowed as a default setting. This allows the top-of-rack (ToR) managed switch to perform all VLAN management related tasks. The external ports of the M I/OA are automatically all part of a single link aggregation group (LAG), and thus there is no need for Spanning-Tree.

The M I/OA provides connectivity to the CNA/Network adapters internally and externally to upstream network devices. Internally the M I/OA provides thirty-two (32) connections. The connections are 10 Gigabit Ethernet connections for basic Ethernet traffic, iSCSI storage traffic, or FCoE storage traffic. In a typical PowerEdge M1000e configuration with 16 half-height blade server ports, 1-16 are used and 17-32 are disabled. If quad port CNA/Network adapters or quarter-height blade servers are used, then ports 17-32 are enabled.

The M I/OA includes two integrated 40Gb Ethernet ports on the base module. These ports are used in a default configuration with a 4 X 10Gb breakout cable to provide four 10Gb links for network traffic. Alternatively these ports can be used as 40Gb links for stacking. The M I/OA also supports three different types of add-in expansion modules, which are called FlexIO Expansion modules. The modules available are: 4-port 10Gbase-T FlexIO module, 4-port 10G SFP+ FlexIO module, and the 2-port 40G QSFP+ FlexIO module. For more information on Dell PowerEdge M I/O Aggregator, see <http://www.dell.com/us/business/p/poweredge-m-io-aggregator/pd>.

Dell Force10 S4810 Switches: The Dell Force10 S-Series S4810 is an ultra-low-latency 10/40 GbE top-of-rack (ToR) switch. Leveraging a non-blocking, cut-through switching architecture, the Force10 S4810 switch delivers line-rate L2 and L3 forwarding capacity with ultra-low latency to maximize network performance. The compact Force10 S4810 switch design provides 48 dual-speed 1/10 GbE (SFP+) ports as well as four 40 GbE QSFP+ uplinks to conserve valuable rack space and simplify the migration to 40 Gbps in the data center core. Dell Force10 S4810 switch incorporates multiple architectural features that optimize data center network flexibility, efficiency, and availability, including Force10's stacking technology, reversible front-to-back or back-to-front airflow for hot/cold aisle environments, and redundant, hot-swappable power supplies and fans. For more information on Dell Force10 switches, see Dell.com/force10.

Dell Force10 S55 Switches: Force10 S-Series S55 1/10 GbE Top-of-Rack switch leverages a non-blocking architecture that delivers line-rate, low-latency L2 and L3 switching to eliminate network bottlenecks. The Force10 S55 switch design provides 48 GbE access ports with up to four modular 10GbE uplinks in 1-RU to conserve valuable rack space. The Force10 S55 switch incorporates multiple architectural features including reversible front-to-back or back-to-front airflow for hot/cold aisle environments and redundant, hot-swappable power supplies and fans. For more information on Dell Force10 switches, see Dell.com/force10.

Dell EqualLogic PS6110 Series Storage: EqualLogic PS6110X 10GbE arrays include Dual 10GbE controllers, high-performance 2.5” SAS HDDs Cache-to-flash memory de-staging and up to 21.6TB of capacity in a 2U chassis.

Management features include:

- Group Manager, which integrates all management into one console for both file and block-storage protocols
- Dell EqualLogic Host Software that extends the functionality of the array-based software to enable cooperation with the host
- Host Integration Tools for Microsoft®, VMware® and Linux® products as well as Dell EqualLogic SAN Headquarters (SAN HQ) management software

Contact your Dell sales representative for more information on Dell EqualLogic PS6110 Series storage configurations and sizing guidelines. <http://www.dell.com/us/enterprise/p/equallogic-ps6110-series?~ck=anav>

Dell PowerEdge R620 Management Server: The management server uses Intel® Xeon® E5-2600 series processors in a 1U rack mount form factor. The server features two CPU sockets and 24 memory DIMM slots supporting 2, 4, 8, 16 or 32GB DIMMs. For more information, see the *Dell PowerEdge R620 guides* at Dell.com/PowerEdge.

4 Design Principles

The following principles are central to the design and architecture of Active System 800m Solution.

1. **Converged Network:** The infrastructure is designed to achieve end-to-end LAN and SAN convergence.
2. **Redundancy to minimize single point of failure:** The system is designed to mitigate failure points. NIC teaming and Multipath I/O (MPIO) are used to provide failover across the redundant network interfaces. iSCSI storage redundancy is achieved with multiple ports and storage controllers. For network traffic, NIC ports are teamed in such a way to distribute traffic across separate ports. The solution also includes redundant power supplies connected to separate Power Distribution Units (PDUs). The solution is further optimized to reduce components such as NICs, cables, and IO Modules, then utilizes hypervisor-based high-availability to provide virtual machine failover. Out-of-Band (OOB) Management is not architected with this level of redundancy since mission critical workloads will continue to operate in the event of an OOB management failure.
3. **Management:** Integrated management using Active System Manager, Dell OpenManage Essentials, EqualLogic SAN HQ, and optional Microsoft System Center VMM 2012 SP1.
4. **Flexible configurations:** Dell Active System 800m is pre-configured to suit most customer needs for a virtualized infrastructure. Each blade server is configured with sufficient CPU, memory, and network adapters. Where desired, the solution also supports processor, memory, and storage options. Additional options, such as wide or deep racks are also available.
5. **Racked, Cabled, and Ready to be deployed:** This Dell Active System is available to be racked, cabled, and delivered to the customer site ready for deployment. Components are configured and racked to optimize airflow and thermals. Based on customer needs, different rack sizes and configurations are available to support various datacenter requirements.

5 Prerequisites and Datacenter Planning

Power, Cooling, and Weight Considerations: Dell Active System 800m solution is configured with PDUs to meet the power requirements of the components, as well as regional constraints. Power consumed, cooling required, and information regarding rack weight are provided to enable customers to plan appropriate power and cooling for the solution.

To support the architecture, the following components are required to be present in the customer environment:

- An existing Ethernet infrastructure with which to integrate. 10Gb or 40Gb Ethernet infrastructure is recommended.
- Additional components, such as Dell Force10 network cables and transceivers, are needed to uplink the solution to the customer network. The necessary components depend upon customer networking and uplink requirements.
- Active Directory® Domain Services (AD DS) must be available on the network. The Hyper-V hosts are joined to an existing or new domain. Cluster Services also require AD DS. Consult with your Dell Sales and Services representatives for more details.
- Domain Name System (DNS) must be available on the management network.
- Database to support System Center 2012 VMM - For a list of supported databases refer to: [Requirements for System Center 2012 - Virtual Machine Manager](#).
 - If IT Administrators wish to install VMM on the Dell PowerEdge R620 Management Server or as a VM, then a route must exist between the management server (physical or as a VM) and the database used.
 - The database is presumed to have maintenance and backup configured as per the business needs of the customer.
- Sufficient power and cooling to support the solution must be present. Detailed power, weight, and cooling requirements for the datacenter are defined in the *Solution Specification Guide for Active System 800 with Microsoft Hyper-V*.

6 Architecture

One of the key attributes of the Dell Active System 800m is the convergence of SAN and LAN over the same network infrastructure. LAN and iSCSI SAN traffic share the same physical connections from servers to storage. The converged network is designed using Data Center Bridging (DCB) (IEEE 802.1) and Data Center Bridging Exchange (DCBX) (IEEE 802.1AB) technologies and features. The converged network design drastically reduces cost and complexity by reducing the components and physical connections and the associated efforts in deploying, configuring, and managing the infrastructure.

Data Center Bridging is a set of related standards to achieve enhanced Ethernet capabilities, especially in datacenter environments, through converge network connectivity. The functionalities provided by DCB and DCBX are:

- **Priority Flow Control (PFC):** This capability provides zero packet loss under congestion by providing a link-level flow control mechanism that can be controlled independently for each priority.
- **Enhanced Transmission Selection (ETS):** This capability provides a framework and mechanism for bandwidth management for different traffic types by assigning bandwidth to different frame priorities.
- **Data Center Bridging Exchange (DCBX):** This functionality is used for conveying the capabilities and configuration of the above features between neighbors to ensure consistent configuration across the network.

Dell Force10 S4810 switches, Dell PowerEdge M I/O Aggregator modules, Broadcom 57810-k Dual port 10GbE KR Blade NDCs, and Dell EqualLogic PS6110 iSCSI SAN arrays enable Dell Active System 800m to utilize these technologies, features, and capabilities to support converged network architecture.

This solution consists of a Dell PowerEdge M1000e chassis populated with Dell PowerEdge M620 blade servers running Windows Server 2012 Data Center Edition. Figure 2 below depicts the high-level reference architecture for the solution, including solution components and redundant connectivity for each I/O fabric.

Reference Architecture for Active System 800m with Hyper-V:

Figure 2: Converged Network Topology (Logical View) with optional 2nd Chassis

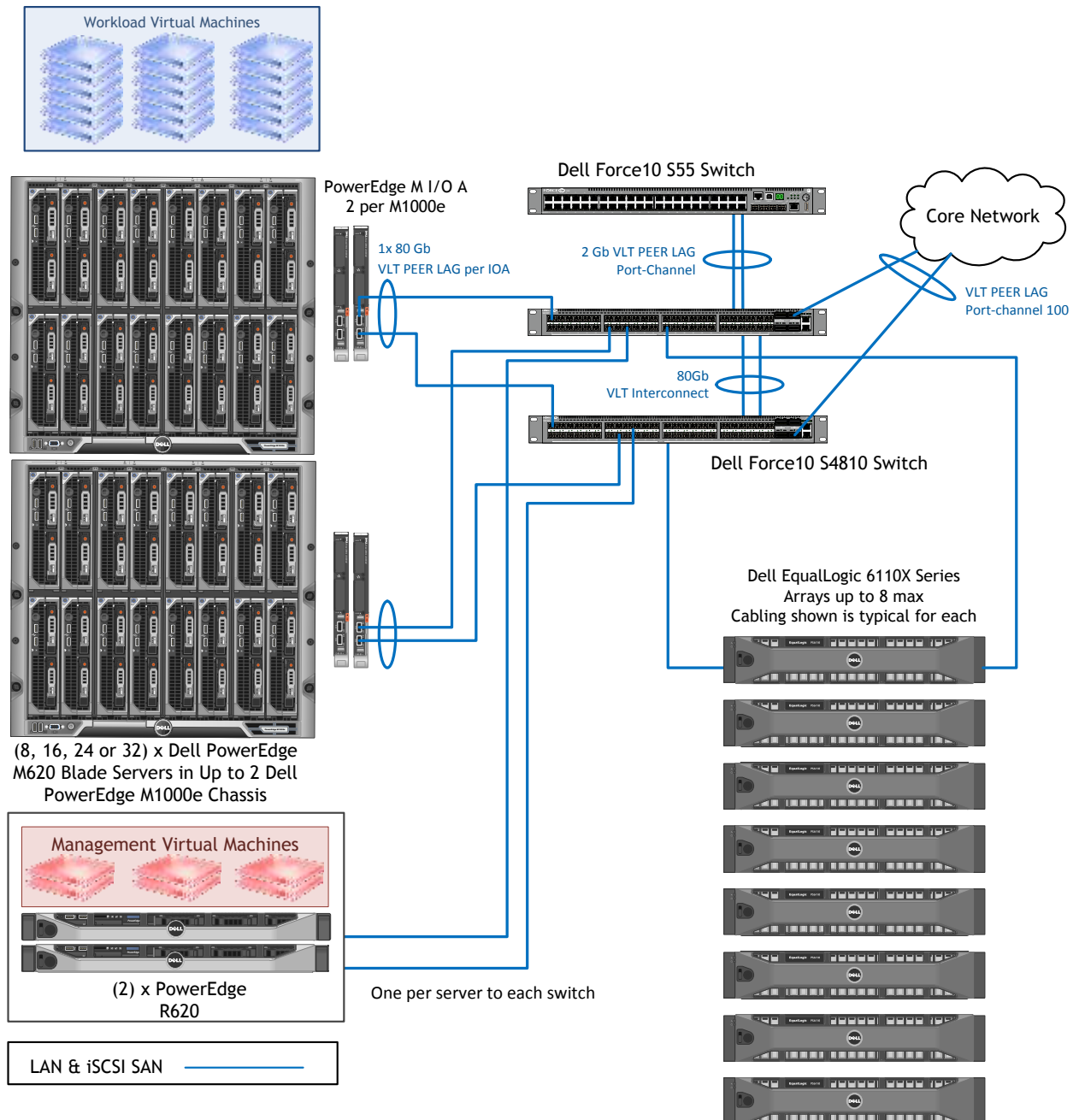

6.1 Dell Blade Network Architecture

In this solution, the Chassis Fabric A contains Dell Force10 IO Aggregator modules and is used for converged LAN and SAN traffic. Fabric B and Fabric C are not used.

M620 blade servers use the Broadcom 57810-k Dual port 10GbE KR Blade NDC to connect to the Fabric A. Dell Force10 IO Aggregator modules uplink to Dell Force10 S4810 network switches providing LAN AND SAN connectivity.

Figure 3 below illustrates how the fabrics are populated in a Dell blade server chassis and how the I/O modules are utilized.

Figure 3: I/O Connectivity for M620 Blade Server

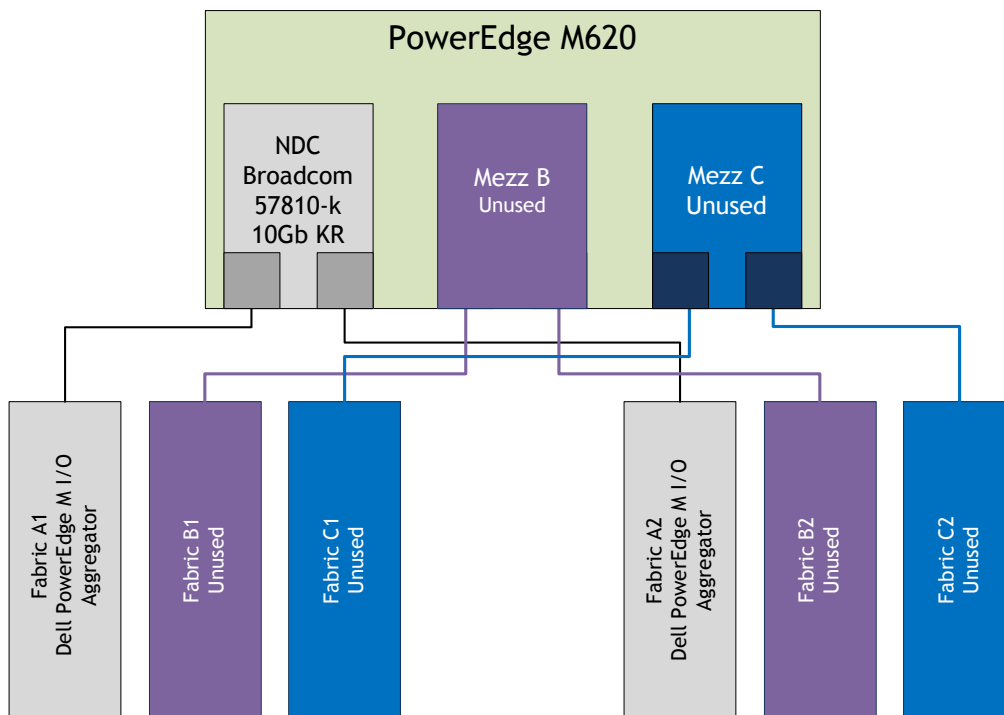

6.2 Server / Blade Network Connectivity

The network traffic on each blade includes iSCSI as well as traffic for the parent partition (hypervisor), Live Migration, cluster heartbeat, cluster shared volume, and child partitions (virtual machines).

A fault-tolerant network team is created by using:

- Two 10 GbE NDC ports for each blade
- A virtual switch is provisioned in Hyper-V
- A virtual network adapter that is:
 - Created
 - Shared with the parent partition
 - Segmented with VLANs
 - Applied with bandwidth weighting

Reference Architecture for Active System 800m with Hyper-V:

Each Dell PowerEdge M620 blade server is configured with a Broadcom BCM57810 bNDC providing two 10GbE ports. These ports are connected to the Dell PowerEdge M I/O Aggregator in Fabric A. The corresponding ports on A1 and A2 modules are connected with the two Dell Force10 S4810 switches outside the blade chassis enclosure. Meanwhile, each PowerEdge R620 rack server is configured with a Broadcom BCM57810 add-in NIC providing two 10Gb SPF+ ports, which are connected with the two Force10 S4810 switches. The two Force10 S4810 switches are configured with a Virtual Line Trunk (VLT) using two 40 Gbps QSFP+ ports in each switch providing an 80Gbps path for communication across the switches. The solution network architecture is illustrated in Figure 4 below.

Figure 4: Converged Fabric Overview

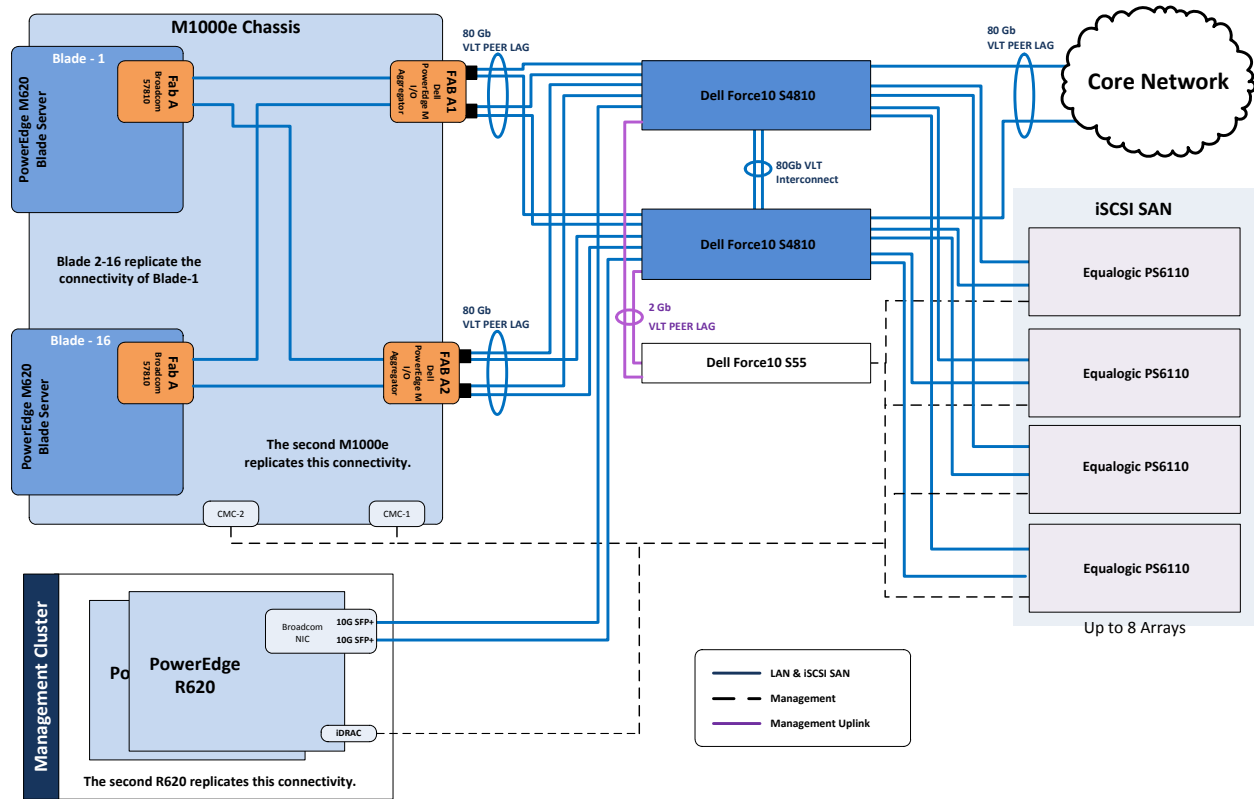

Figure 5 illustrates the converged network configuration and DCB settings for the PowerEdge M620 blade server. Figure 6 illustrates the configuration for the PowerEdge R620 management servers.

The VLAN IDs are assigned to the virtual network adapters assigned to the parent partition to segregate the traffic on the host between the cluster, Live Migration, parent management, and other types of traffic that are described in Table 2 below. The VLAN configuration used in the Dell Active System configuration is listed in Table 3.

Figure 5: Converged Network configuration for Compute Dell PowerEdge M620 Blade Servers

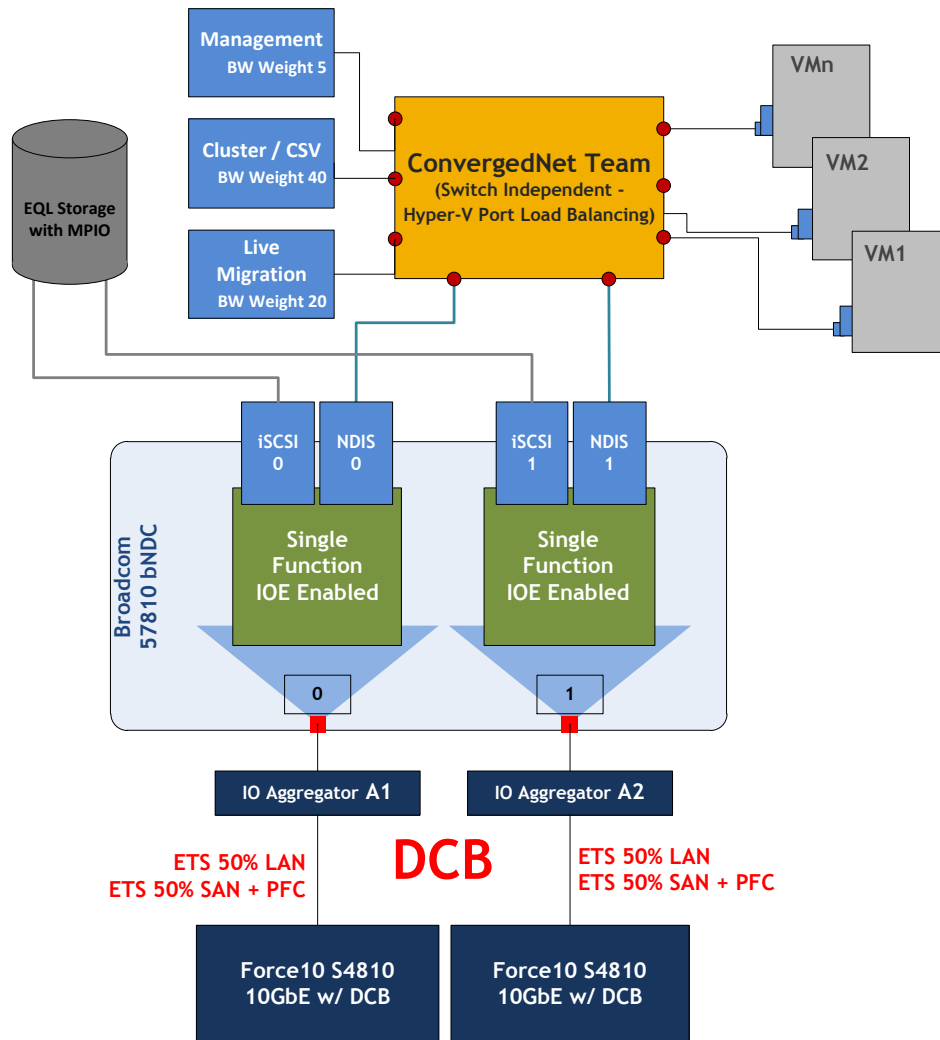

Figure 6: Converged Network Configuration for Management of Dell PowerEdge R620 Servers

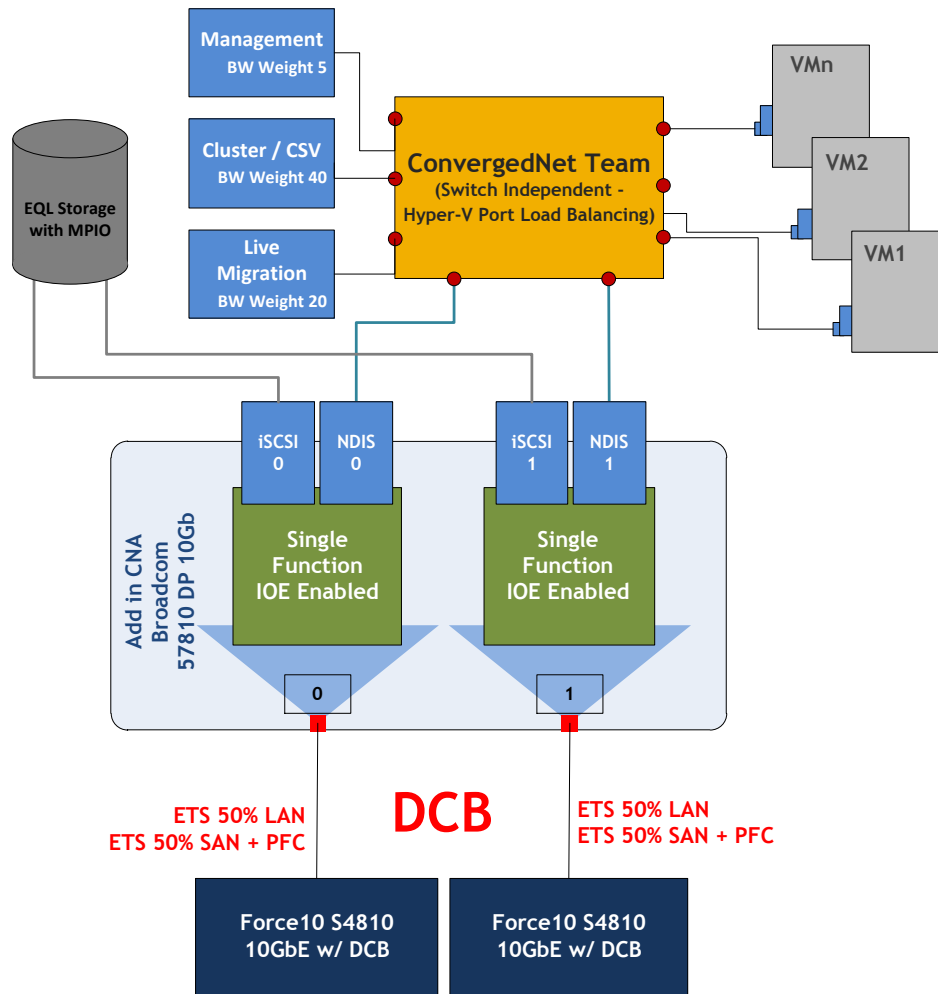

Table 2: Traffic Description

Traffic Type	Use
Compute Node Hypervisor	Supports virtualization management traffic and communication between the host servers in the cluster.
Compute Live Migration	Supports migration of VMs between the host servers in the cluster.
Tenant VM	Supports communication between the VMs hosted on the cluster and external systems.
Compute Cluster	Supports internal cluster network communication between the servers in the cluster.
Out-of-Band Management	Supports configuration and monitoring of the servers through the iDRAC management interface, storage arrays, and network switches.
iSCSI Data	Supports iSCSI traffic between the servers and storage array(s). In addition, traffic between the arrays is supported.

Traffic Type	Use
Management Node Hypervisor	Supports virtualization management traffic and communication between the management servers in the cluster.
Management Cluster	Supports private cluster traffic for the management clusters.
Management Live Migration	Supports migration of VMs between the management servers in the cluster.
Management Tenant VM	Supports the virtual machine traffic for the management virtual machines.
Guest Clustering	Supports the private cluster communication required for SQL Clustering.

Table 3: Sample VLAN and subnet configuration

Traffic Type	Sample VLAN	Sample Subnet
Out-of-Band Management	24	10.110.4.0/24
Compute Node Management	20	10.110.0.0/24
Compute Live Migration	21	10.110.1.0/24
Compute Cluster Private	22	10.110.2.0/24
Management Tenant VM	23	10.110.3.0/24
iSCSI	25	10.110.5.0/24
Management Hypervisor	26	10.110.6.0/24
Management Cluster LM	27	10.110.7.0/24
Management Cluster Private	28	10.110.8.0/24
Guest Clustering (Microsoft FastTrack)	30	10.110.10.0/24
Tenant VM	32	10.110.12.0/22

6.3 Server / Blade Storage Connectivity

In the Dell Active System configuration, each PowerEdge M620 and R620 server uses an internal Dell PERC H710 RAID controller and is connected to two SAS HDDs configured in a RAID-1. This RAID volume hosts Windows Server 2012 for the hypervisor operating system.

Each server also includes Broadcom BCM 57810 Converged Network Adapter for attaching to SAN volumes.

6.4 Server / Blade HA and Redundancy

The PowerEdge M620 blade chassis enclosure M1000e is designed with redundant power supplies and redundant fans. Each PowerEdge M620 uses a Dell PERC H710 RAID controller and two hard drives configured in a RAID-1, which hosts the parent operating system.

The design of PowerEdge R620 servers includes high availability and redundant features such as redundant fans and power supplies that are distributed to independent power sources. The servers also use PERC H710 controllers with two hard disks configured with RAID-1 to prevent server crashes in the event of single disk failures.

6.5 Storage Architecture

Dell EqualLogic PS6110 provides capabilities essential to the Active System 800m design, like 10Gb connectivity, flexibility in configuring RAID arrays and creating volumes, thin provisioning, and storage tiering.

6.5.1 EqualLogic Group and Pool Configuration

Each EqualLogic array (or member) is assigned to a particular group. Groups help in simplifying management by enabling management of all members in a group from a single interface. Each group contains one or more storage pools. Each pool must contain one or more members and each member is associated with only one storage pool.

The iSCSI volumes are created at the pool level. In the case where multiple members are placed in a single pool, the data is distributed amongst the members of the pool. With data being distributed over a larger number of disks, the potential performance of iSCSI volumes within the pool is increased with each member added.

6.5.1.1 Storage Network

Figure 7 below illustrates the SAN Connectivity. Each Dell PowerEdge M620 blade server is configured with a Broadcom BCM 57810 Converged Network Adapter Network Daughter Card. The BCM 57810 enumerates an iSCSI initiator device in addition to the standard LAN device, resulting in a converged network fabric. Each port is wired across the Dell PowerEdge M1000e mid-plane to the Dell PowerEdge M I/O Aggregators in Fabric A. These modules are trunked to the Dell Force10 S4810 ToR switches. The 10 GbE ports of Dell EqualLogic PS6110 Series are also connected to the S4810 ToR switches. For the management servers, each PowerEdge R620 server is configured with a BCM 57810 Add-in PCI-E Card and connected to the Force10 S4810 switches.

Both the blade servers and the rack servers utilize DCB to guarantee traffic flows from each node to the SAN. The DCB configuration utilizes DCBX, PFC, and ETS. The DCB settings default to allow 50% bandwidth for LAN traffic and 50% for SAN traffic. These ETS settings are configurable based upon customer requirements. The PFC settings are configured to be lossless for the iSCSI queue.

Figure 7: Active System SAN Connectivity Overview

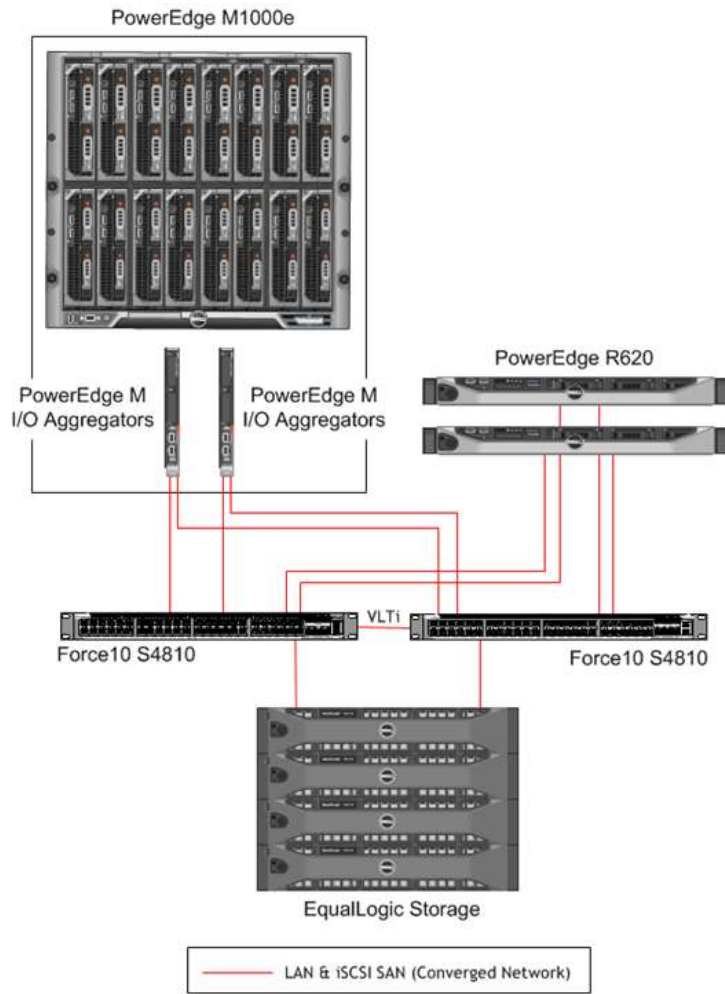

6.5.1.2 Performance

Dell EqualLogic PS6110 Series uses a redundant controller architecture with a single active 10GbE front-end port per controller. To allow the network port to dedicate the 10GbE bandwidth to SAN traffic, the 1GbE out-of-band port is used for configuration and performance monitoring.

6.5.1.3 Drive Types

The Dell EqualLogic PS6110 Series arrays use a high performance 10K RPM SAS drive in the default configuration. This provides a balance of size and performance. The EqualLogic PS6110 is available with drives in multiple speeds and sizes, including 10K RPM and 15K RPM SAS drives, 7.2K RPM NL-SAS drives, and solid-state disks.

6.5.1.4 RAID Array Design

The storage array RAID configuration is highly dependent on the workload in your virtual environment. The EqualLogic PS series storage arrays support RAID types: RAID 6, RAID 10, and RAID 50. The RAID configuration will depend on workloads and customer requirements. In general, RAID 10 provides the best performance at the expense of storage capacity, especially in random I/O situations. RAID 50 generally provides more usable storage, but has less performance than RAID 10. RAID 6 provides better data protection than RAID 50.

For more information on configuring RAID in EqualLogic, refer to the white paper, [How to Select the Correct RAID for an EqualLogic SAN](#).

6.5.1.5 Storage Tiering

Tiering storage is the practice of physically partitioning data into multiple distinct classes based on price, performance, or other attributes. Data may be dynamically moved among classes in a tiered storage implementation based on access activity or other considerations.

This is normally achieved through a combination of varying types of disks which are used for different data types. (i.e. Production, non-production, backups, etc.) Dell EqualLogic PS6110 Series dynamically moves data to the optimal storage tier based on actual use. The most active blocks reside on high-performance SSD and SAS drives, while infrequently accessed data migrates to lower-cost, high-capacity SAS drives. The result is network storage that remains in tune with application needs.

6.5.1.6 High Availability

In order to maintain continuous connectivity to stored data from the server, the controllers of the EqualLogic PS6110 have vertical port failover from active to standby controller. This port failover mechanism allows a port to failover without having to failover the controller. This results in a lower time that a controller is unavailable.

6.5.1.7 Multi-pathing

For Windows Server 2012, the native MPIO provides functionality for Dell EqualLogic. The EqualLogic Host Integration Tools (HIT) kit provides enhanced load balancing and additional EqualLogic tools like the PowerShell module for group management and the Auto-Snapshot Manager. The multi-pathing solution uses the round-robin load balancing algorithm to utilize all available paths. Dell recommends the EqualLogic Hit kit for its enhanced functionality and performance but either can be used.

6.5.1.8 iSCSI Encryption and Authentication

Challenge Handshake Authentication Protocol (CHAP) is available for use on the EqualLogic PS6110 Series Storage Center. This feature allows hosts to authenticate to the EqualLogic PS6110 iSCSI target prior to the target being available for use on the system.

6.5.1.9 Jumbo Frames

In the Dell Active System configuration, Jumbo Frames are enabled for all devices of the iSCSI SAN fabric. This includes the server network interface ports, the network switch interfaces, and the EqualLogic PS6110 Series interfaces.

6.5.1.10 Thin Provisioning

Particularly in virtualization environments, thin provisioning is a common practice. This allows for efficient use of the available storage capacity. The volume and corresponding CSV may grow as needed, typically in an automated fashion to ensure availability of the volume. However, as storage becomes over-provisioned in this scenario, very careful management and capacity planning is critical.

EqualLogic PS6110 Series offers Thin Provisioning and eliminates pre-allocated but unused capacity.

7 Management Infrastructure

Within the Active System 800m solution, two Dell PowerEdge R620 servers and one Dell Force10 S55 1/10GbE Ethernet switch are used for the management infrastructure. The Force10 S55 switch is used for out-of-band management connectivity for Dell CMC, Dell iDRAC, and the management ports on Dell EqualLogic arrays. The management cluster infrastructure imitates the compute cluster in using converged network infrastructure and configuration. The PowerEdge R620 servers are connected to the Force10 S4810 switches using Broadcom 57810 Dual Port 10Gb network adapters. The management servers are connected to the EqualLogic storage through the two Force10 S4810 switches.

Note that the EqualLogic storage is shared between the management cluster and the compute cluster. The EqualLogic storage must be sized so that sufficient capacity and bandwidth are allocated for both the management VMs and compute VMs.

The PowerEdge R620 servers run Windows Server 2012 with Hyper-V role enabled and are a part of the unique management cluster.

The following management components are included in the Active System 800m:

- Dell Active System Manager
- Dell OpenManage Essentials (OME)
- Dell EqualLogic SAN HeadQuarters (SAN HQ)
- Optional: System Center 2012 SP1 Virtual Machine Manager

These components are installed in virtual machines in the management infrastructure as illustrated in Figure 8 below.

Figure 8: Management Architecture

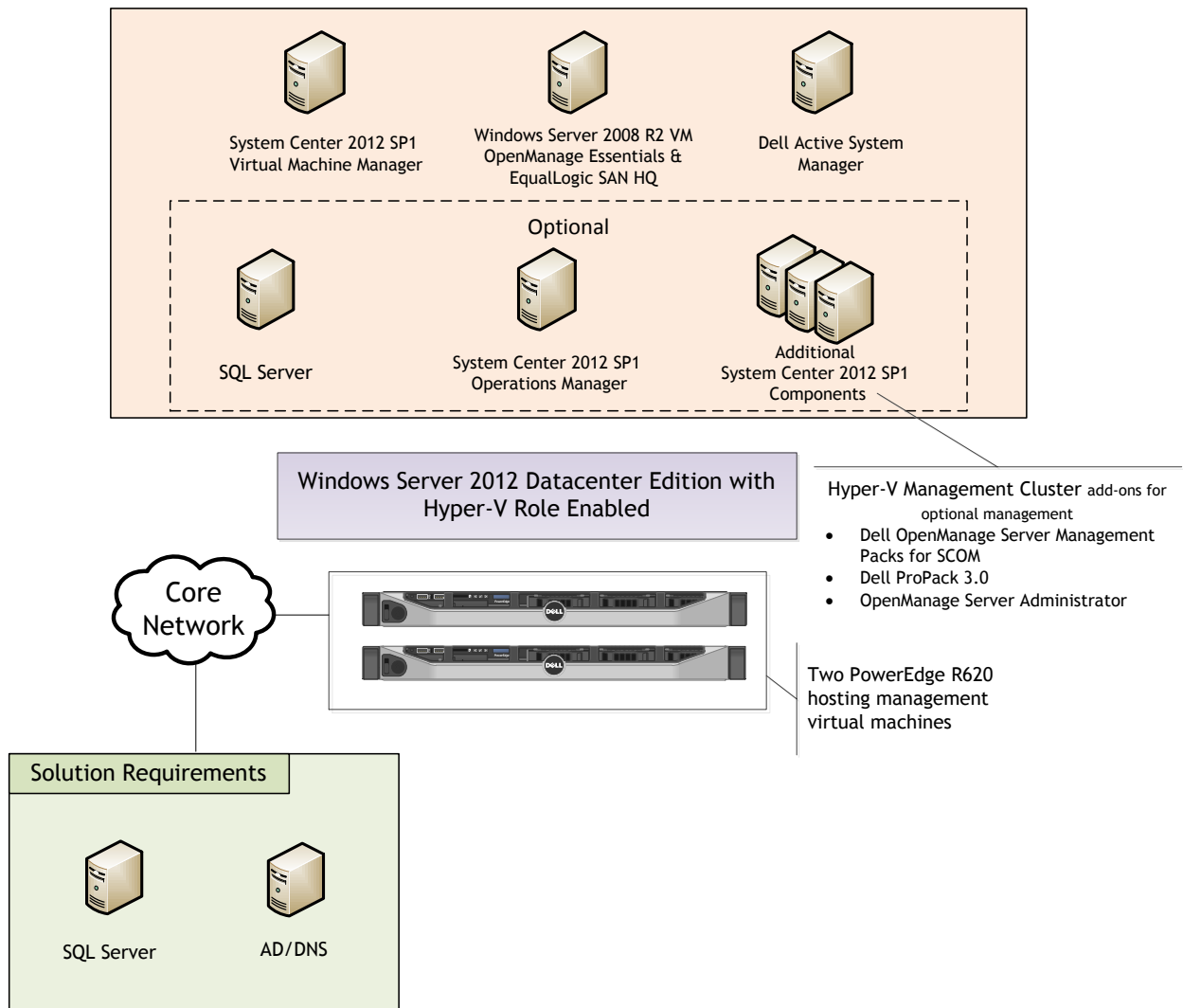

The management infrastructure components are described in more detail in the following sections.

7.1 Active System Manager

Active System Manager is an intelligent and intuitive converged infrastructure and workload manager. Active System Manager leverages templates to automate infrastructure provisioning, on-boarding, and re-configuration, which greatly simplifies and speeds up the process, and also significantly reduces errors associated with manual configuration. The result is better infrastructure and workload quality with fewer configuration errors that can be costly. Key features provided with Active System Manager:

- **Template-Based Provisioning** – Streamline and standardize workload deployments through centralized capture and application of best practices & operational steps
- **Infrastructure Lifecycle Mgmt** – Discovery, inventory, configuration, provisioning, and ongoing management of physical and virtual infrastructure
- **Resource Pooling & Dynamic Allocation** – Create and manage physical and virtual resource pools; efficiently schedule or allocate resources on-demand
- **End-To-End Automation** – Multi-tier automation across physical (server, storage and network) and virtual layers
- **Workflow Orchestration** – Intelligent workflow orchestration engine for rapid physical and virtual workload provisioning
- **Centralized Management** – Intuitive centralized, role-based management and access through self-service web portal

Note: Active System Manager offers limited functionality on Microsoft Hyper-V platforms with Active System Manager version 7.0. The capabilities and benefits outlined above will be available on the Microsoft Hyper-V platforms with the Active System Manager version 7.1 scheduled for release in mid 2013.

7.2 Microsoft Windows Server 2012 Built-In tools

Windows Server 2012 provides the following built-in new or updated management features and tools for the virtualization solution:

- **Server Manager:** Server Manager in Windows Server 2012 is re-designed as the primary management console for all the systems including the remote servers in an environment. Server Manager also manages the virtual machines and installed Windows roles on all managed systems. It includes a role-based dashboard, which aggregates the data from managed servers. It reports system health state and surfaces issues which require attention. The Server Manager also creates customized groups for managed systems. Figure 9 illustrates an example of managing a Dell Active System 800m with Server Manager.

Figure 9: Manage Active System 800m with Server Manager

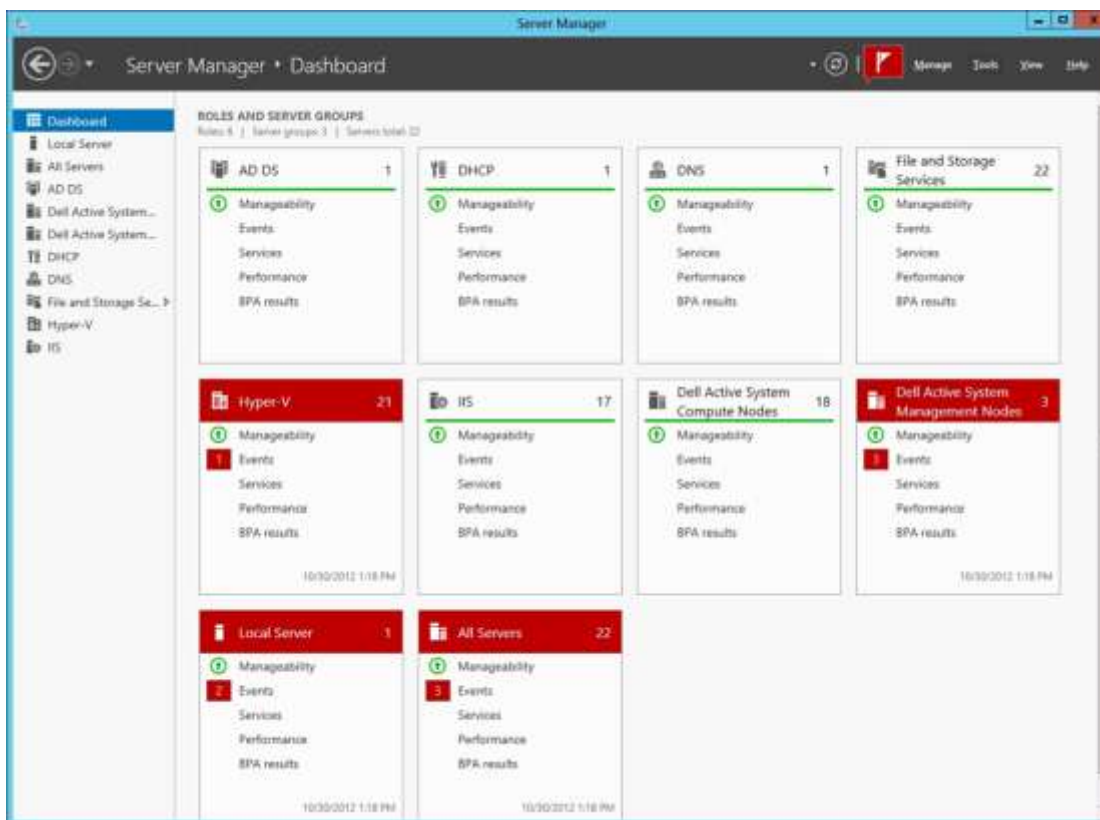

- **Hyper-V Manager:** In Windows Server 2012, more than 160 PowerShell command-lets (cmdlets) were added for Hyper-V. On the host management, Hyper-V Manager allows the configuring of physical Graphics Processing Unit (GPU), Live Migrations, storage migration, and Hyper-V replication. For virtual machine management, Hyper-V Manager includes more VM configuration, such as FC Adapter, VM NUMA, NIC HW acceleration (VMQ, IPsec, SR-IOV) and advanced features on MAC spoofing, DHCP guard, Router guard, port mirroring, and NIC teaming. Also, VM management includes the support of Hyper-V Replica.
- **Failover Cluster Manager:** With Failover Cluster Manager, the host configuration is validated for a Failover Cluster. Multiple failover clusters and high-availability virtual machines are created, configured and managed with the Failover Cluster Manager. In Windows Server 2012, the Failover Cluster Manager adds support for storage space, Hyper-V Replica, and new types of Live Migration. It also reports VM health states with more details, including Replication State, and allows monitoring of the services running inside VMs.
- **PowerShell 3.0:** Several significant features are included in PowerShell 3.0 which eases and extends the management in the Windows-based environment. PowerShell 3.0 adds modules for Hyper-V, storage, and network, etc. Hyper-V cmdlets help automate the Hyper-V management tasks. With PowerShell 3.0, the resource utilization of VMs can be measured. This helps dynamic chargeback (vs. flat upfront cost) and capacity planning. Figure 10 shows an example of how to measure a VM with PowerShell 3.0.

Figure 10: Resources Measuring in PowerShell 3.0

```

PS C:\Users\administrator.HER3> Enable-VMResourceMetering -VMName SQLSCVMMDB
PS C:\Users\administrator.HER3> Add-VMNetworkAdapterACL -VMName SQLSCVMMDB -Action Meter -Direction Inbound -RemoteIPAdd
ress 10.10.0.0/16
PS C:\Users\administrator.HER3> Add-VMNetworkAdapterACL -VMName SQLSCVMMDB -Action Meter -Direction Outbound -RemoteIPAd
dress 10.100.0.0/16
PS C:\Users\administrator.HER3> $report=Measure-VM -VMName SQLSCVMMDB
PS C:\Users\administrator.HER3> $report | Format-List

ComputerName      : R610-2
VMId              : 280cdd17-e5aa-4a28-8706-caa1fa7ce05f
VMName           : SQLSCVMMDB
MeteringDuration  : 00:03:44.6070000
AverageProcessorUsage : 664
AverageMemoryUsage : 4062
MaximumMemoryUsage : 4096
MinimumMemoryUsage : 4096
TotalDiskAllocation : 61440
NetworkMeteredTrafficReport : {Microsoft.HyperV.PowerShell.VMNetworkAdapterPortACLMeteringReport,
Microsoft.HyperV.PowerShell.VMNetworkAdapterPortACLMeteringReport,
Microsoft.HyperV.PowerShell.VMNetworkAdapterPortACLMeteringReport,
Microsoft.HyperV.PowerShell.VMNetworkAdapterPortACLMeteringReport...}
AvgCPU           : 664
AvgRAM           : 4062
MinRAM           : 4096
MaxRAM           : 4096
TotalDisk        : 61440

PS C:\Users\administrator.HER3> $report.NetworkMeteredTrafficReport

LocalAddress RemoteAddress Direction TotalTraffic(M)
-----
::/0 Outbound 0
10.10.0.0/16 Inbound 1529
0.0.0.0/0 Inbound 1
::/0 Inbound 1
0.0.0.0/0 Outbound 7
10.100.0.0/16 Outbound 0
0.0.0.0/0 Inbound 126
::/0 Outbound 0
0.0.0.0/0 Outbound 1
10.100.0.0/16 Outbound 8487
10.10.0.0/16 Inbound 0
::/0 Inbound 1

```

CPU (MHz): Across hosts if LM.

Memory (MB): Average, Minimum and Maximum.

Disk (MB): VHD and the snapshots.

Network (MB): Use ACLs to separate traffics. Each ACL includes:

- **Direction:** Inbound vs. Outbound
- **Remote IP:** the source or destination of the network packet, depending on direction.

7.3 Dell OpenManage Essentials

Dell OpenManage Essentials (OME) is a system management console that provides simple, basic Dell hardware management. Dell OME 1.1 manages the host running Windows Server 2012. It supports agent-free hardware inventory and system update (e.g., BIOS, firmware) for the 11th and 12th generations of Dell PowerEdge servers. It also adds Dell SupportAssist extension for proactive “phone home” hardware issue resolution. Figure 11 shows the dashboard of Dell OME. Other features in Dell OME 1.1 are:

- Discover, Inventory, monitor health, and view logs of Dell clients (i.e., desktops, portables)
- Discover, Inventory, and monitor health of Dell Force 10 Switches, Dell PDU and UPS devices
- Discover and collect limited inventory Linux servers via Secure Shell (SSH)
- Enhanced hardware inventory for ESXi servers with Dell OpenManage Server Administrator (OMSA)
- Alerts for hardware health status changes (not just when a hardware trap is sent)
- Ability to forward alerts in original format to support tiered event management
- A new command line interface (CLI) for automation of server discovery and grouping
- Calendar style task schedule view
- Group filtering on portal pages
- More configurable portal pages
- Grouped discovery ranges for common protocol settings
- Custom URL launch points to allow user-defined right-click actions on devices

For more information on OpenManage Essentials, see www.delltechcenter.com/ome.

Figure 11: OME Dashboard



Dell Lifecycle Controller: Helps to reduce operating costs by simplifying server deployment and management. Key features include diagnostics, self-update (UEFI, Driver Pack update), firmware updates (BIOS, NIC FW, RAID Controllers), and hardware configuration. Also, the integrated iDRAC provides the mechanism for OME agentless management.

Dell OpenManage Server Administrator (OMSA): Dell OMSA provides a comprehensive, one-to-one systems management solution. OMSA provides the mechanism for the agent-based management for Dell OME. With agent-based management, OME can update the device drivers on the host in addition to other management capabilities provided by the agentless management. For more information, see <http://www.delltechcenter.com/page/OpenManage+Server+Administrator+-+OMSA>.

7.4 Dell EqualLogic SAN HQ

Dell EqualLogic SAN HQ provides comprehensive monitoring of performance and health statistics for one or more EqualLogic PS Series groups. The tool is a client/server application that runs on a Microsoft Windows server and uses SNMP to query the groups. Acting as a “flight data recorder” on an aircraft, SAN HQ collects data over time and stores it on the server for later retrieval and analysis. Client systems connect to the server and format and display the data in the Dell SAN HQ GUI.

Dell SAN HQ can:

- Monitor one or more PS Series groups and store operational data for up to a year
- Obtain a centralized view of the health and status of multiple groups
- View IO rates, throughput, and latency for each volume, member, pool, or group
- Allow the same performance data to be viewed by multiple clients simultaneously
- Monitor and analyze capacity usage for groups

If action is required, launch the Dell EqualLogic Group Manager directly from SAN HQ to quickly adjust storage systems to meet business needs.

7.5 Out-of-band Management: CMC and iDRAC

The CMC provides a single, secure interface to manage the inventory, configuration, monitoring, and alerting for chassis components (iKVM, CMC), I/O modules, servers, and iDRAC. It also provides excellent real-time power management, monitoring, and alerting capabilities. The Dell chassis provides users with system-level power limiting, slot-based prioritization, and dynamic power engagement functionalities. The iDRAC on each server provides the flexibility to remotely manage the server through console redirection and Virtual CD-ROM/DVD/Floppy/Flash capabilities.

7.6 System Center 2012 SP1

System Center 2012 Virtual Machine Manager SP1. VMM 2012 is Microsoft's virtualization management platform. VMM 2012 provides in-depth management of both hypervisor and VMs. It provides a system administrator the capability to create and deploy VM templates, manage library stores of VMs, hardware profiles, and image files, and even manage VMware environments. VMM 2012 also provides P2V (physical to virtual) functionality, thereby allowing a system administrator to convert physical servers to virtual machines. VMM 2012 integrates with the hypervisor, VMs, and System Center Operations Manager to provide a deep view of the system utilization.

VMM 2012 SP1 introduces the following new features:

- **Network Virtualization:** Provides the ability to run multiple virtual network infrastructures, even with overlapping IP addresses, on the same physical network. There are two mechanisms to virtualize the IP address of a virtual machine: IP Rewrite or IP encapsulation.
- **VHDX Support:** Supports converting from .vhd to vhdx. When creating a new virtual machine with a blank virtual hard disk, VMM determines the VHD format based on the operating system of the destination host.
- **Storage Management Enhancements:** Supports the new Windows Standard-based Storage Management service, which enables discovering storage by using multiple provider types. It also supports thin provisioning of logical units, and the discovery of SAS storage.
- **Host Provisioning Enhancement:** Support for performing Deep Discovery to retrieve more detailed information about the physical computer hardware before deploying the OS.

- **SMB 3.0 File Shares:** Support for designating network file shares on Windows Server 2012 computers as the storage location for virtual machine files, such as configuration, virtual hard disk files, and checkpoints.
- **Live Migration Enhancements:** Supports performing simultaneous Live Migrations with options like Live, Live VSM, and Live Storage.

7.7 Dell System Center 2012 Integration

Dell provides management packs for the optional System Center components to monitor servers, storage, and networking components. These management packs allow System Center 2012 Operations Manager (SCOM) to monitor, report, and take actions based upon alerts generated by the individual components. Dell Server PRO Management Packs can be integrated with VMM to monitor Dell servers and take remedial action when an inefficient system is identified.

Dell also provides integration tools for System Center Configuration Manager for the Lifecycle Controller, providing a framework for bare-metal deployment of servers and operating systems. Dell EqualLogic PS6110 Series also includes management tools for automating the deployment of virtual machines with VMM 2012 SP1. These optional components are beyond the scope of this document. Additional information can be obtained from your Dell Sales or Services representative.

7.8 Out-Of-Band Management Connectivity

The Dell Force10 S55 switch is used as a 1GbE out-of-band management switch. Each of the solution components is connected to the Force10 S55 as shown in Figure 12. The Force10 S55 switch is uplinked to each of the Force10 S4810 switches for core network connectivity.

Figure 12: Connectivity of OOB management components.

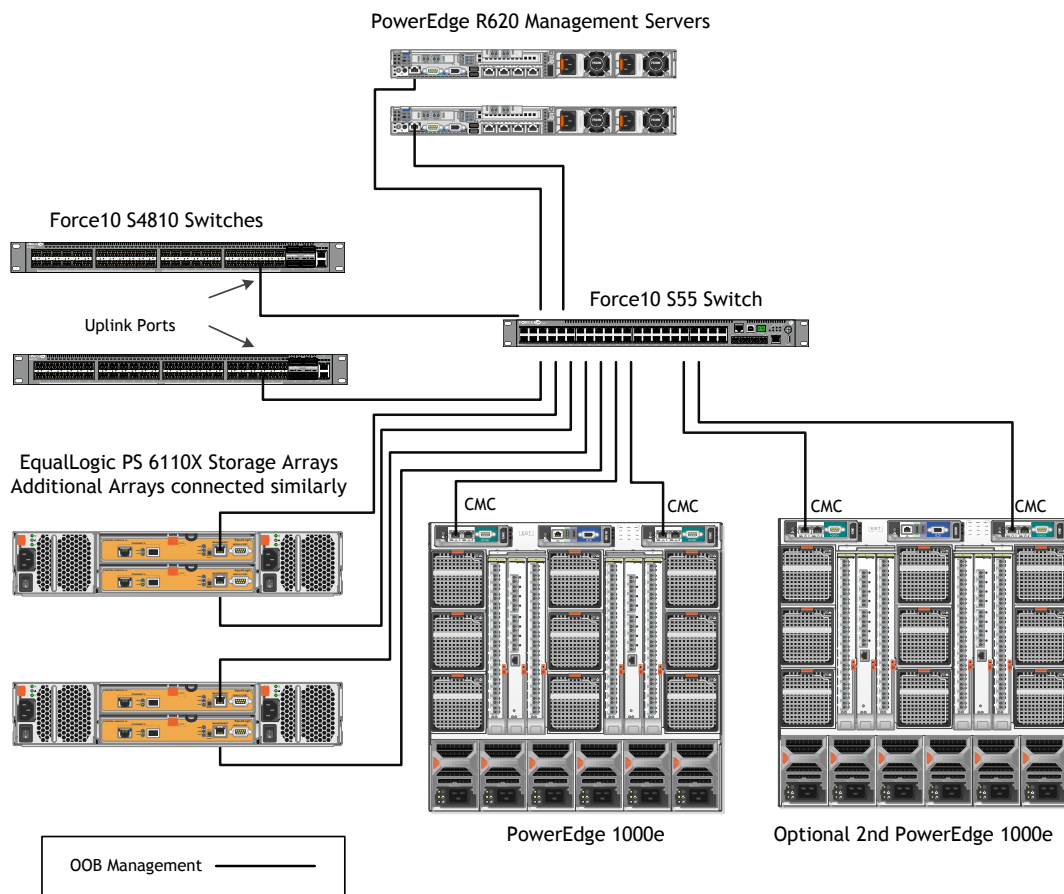

8 Scalability

As workloads increase, the solution can be scaled to provide additional compute and storage resources independently.

Scaling Compute and Network Resources: This solution is configured with two Dell Force10 S4810 network switches. Up to two Dell PowerEdge M1000e chassis can be added to the two Force10 switches.

Scaling Storage Resources: Dell EqualLogic PS6110 Series storage can be scaled seamlessly and independent of the compute and network architectures. This design is currently limited to four enclosures in the single rack configuration and eight enclosures in the two rack configurations.

9 Delivery Model

The Dell Active System 800m reference architecture can be purchased as a complete solution. This solution is available to be racked, cabled, and delivered to the customer site to speed deployment. Dell Services deploys and configures the solution tailored to the business needs of the customer and the architecture is developed and validated by Dell Engineering. For more details or questions about the delivery model, please consult with your Dell Sales representative.

Reference Architecture for Active System 800m with Hyper-V:

Figure 13 below shows the Dell Active System 800m solution with a single chassis. Figure 14 shows Dell Active System 800m with two chassis and the maximum number of storage enclosures. Note that the switches shown in the figures below are shown mounted forward for representation. In actual use, ports face the back of the rack. PDUs shown are for illustration and vary by region or customer power requirements. Additional PDUs are utilized within the rack.

Figure 13: Dell Active System 800m Rack and Component Overview

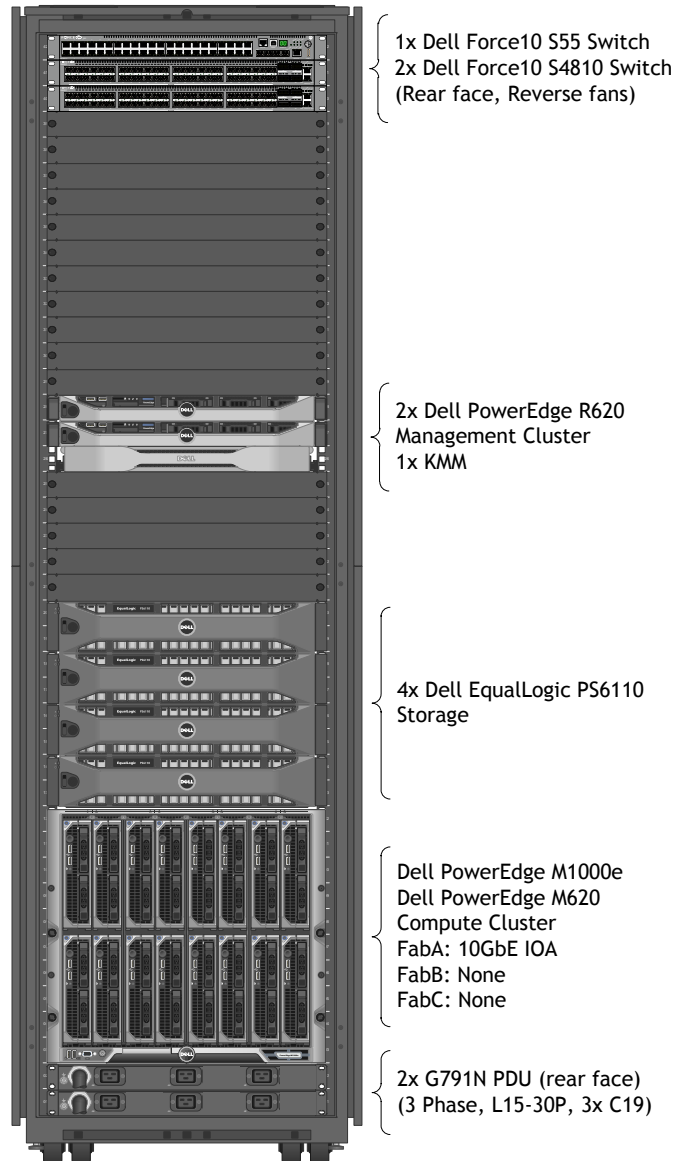

The Dell Active System design shown in Figure 13 above accommodates up to 16 compute hosts in a one rack configuration that also contains Dell EqualLogic PS6110 Series storage.

Figure 14: Dell Active System 800m Maximum 2 Rack Component Overview

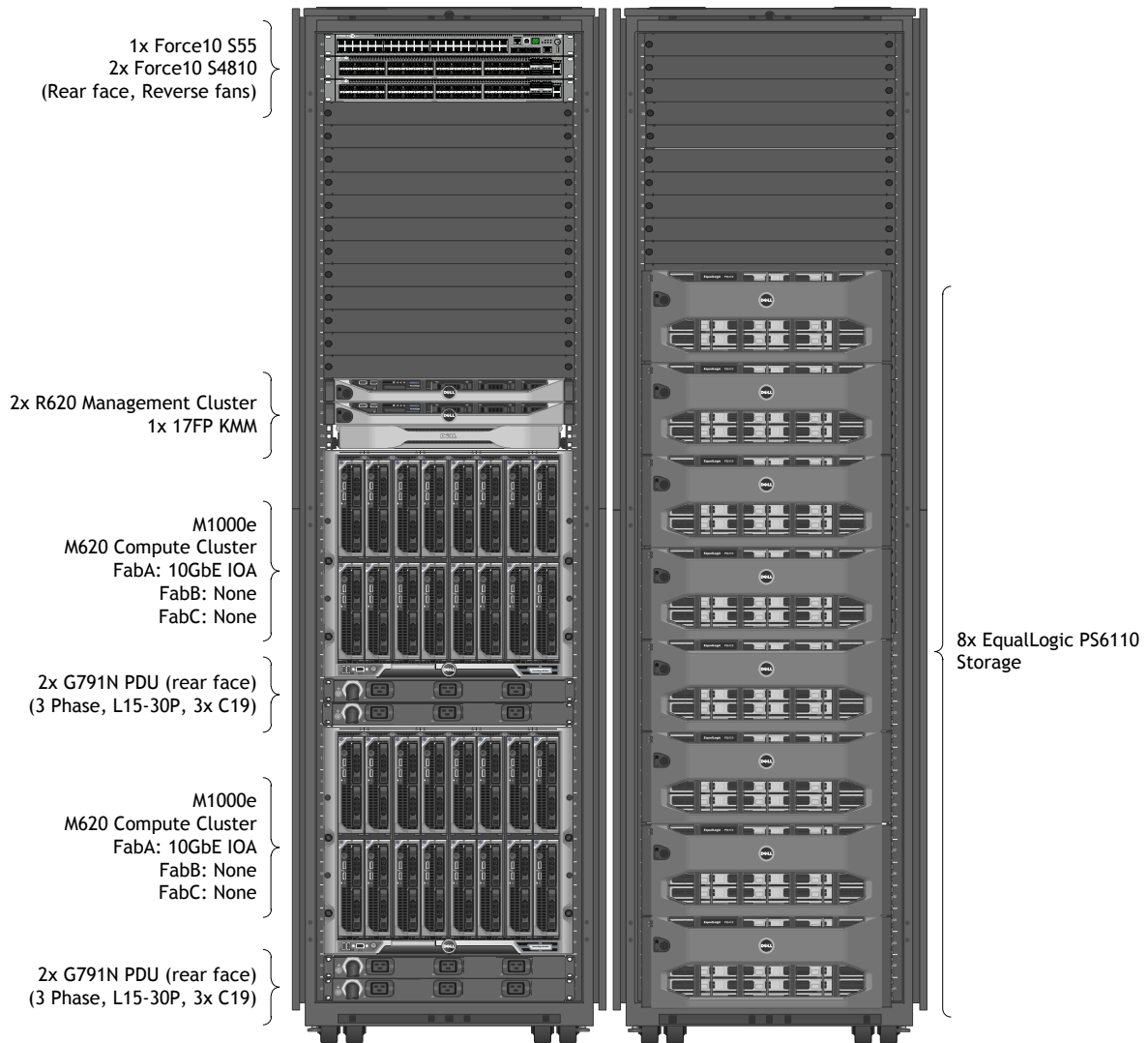

The Dell Active System design shown in Figure 14 accommodates up to 32 compute hosts along with eight Dell EqualLogic PS6110 Series 2U or 4U storage enclosures in a two rack configuration.

10 References

10.1 Dell PowerEdge Server Documentation and Hardware/Software Updates

For drivers and other downloads: Visit <http://support.dell.com>, click “Start Here” for Enterprise IT, “Select a product”, then enter a server service tag or select the server model and operating system version.

10.2 Dell Force10 Switch Documentation and Firmware Updates

Visit <http://support.dell.com> or click [here](#) for directions to sign onto your Force10 Online Support account.

10.3 Dell EqualLogic:

- Dell EqualLogic PS Series Architecture Whitepaper
http://www.dell.com/downloads/global/products/pvaul/en/dell_equallogic_architecture.pdf
- Host Integration Tools for Windows
<http://www.dell.com/downloads/global/products/pvaul/en/equallogic-host-software.pdf>
- PS Series Storage Arrays: Choosing a Member RAID Policy
<http://www.equallogic.com/WorkArea/DownloadAsset.aspx?id=5231>
- Using Tiered Storage in a PS Series SAN
<http://www.equallogic.com/resourcecenter/assetview.aspx?id=5239>
- Monitoring your PS Series SAN with SAN HQ
<http://www.equallogic.com/resourcecenter/assetview.aspx?id=8749>

10.4 Dell Virtualization Documentation

Microsoft® Windows Server® 2012 With Hyper-V™ for Dell™ PowerEdge™ Systems Important Information Guide:

http://support.dell.com/support/topics/global.aspx/support/windows_server_support/windows-server?c=us&cs=555&l=en&s=biz

Reference Architecture for Active System 800m with Hyper-V:

10.5 Microsoft® Hyper-V Documentation

Windows Server 2012

<http://technet.microsoft.com/en-us/library/hh801901>

Windows Server 2012 Hyper-V Whitepaper

http://download.microsoft.com/download/5/D/B/5DB1C7BF-6286-4431-A244-438D4605DB1D/WS%202012%20White%20Paper_Hyper-V.pdf.

Failover Clusters in Windows Server 2012

<http://technet.microsoft.com/en-us/library/hh831579>

10.6 Microsoft® Management Software

Microsoft System Center 2012 SP1:

<http://www.microsoft.com/en-us/server-cloud/system-center/datacenter-management.aspx>

System Center 2012 Virtual Machine Manager Deployment:

<http://technet.microsoft.com/en-us/library/gg610669>